

**ROAD CROSS SECTION AT WETLAND CROSSING (A-A)**  
SCALE: 1"=5' (HORIZONTAL & VERTICAL)

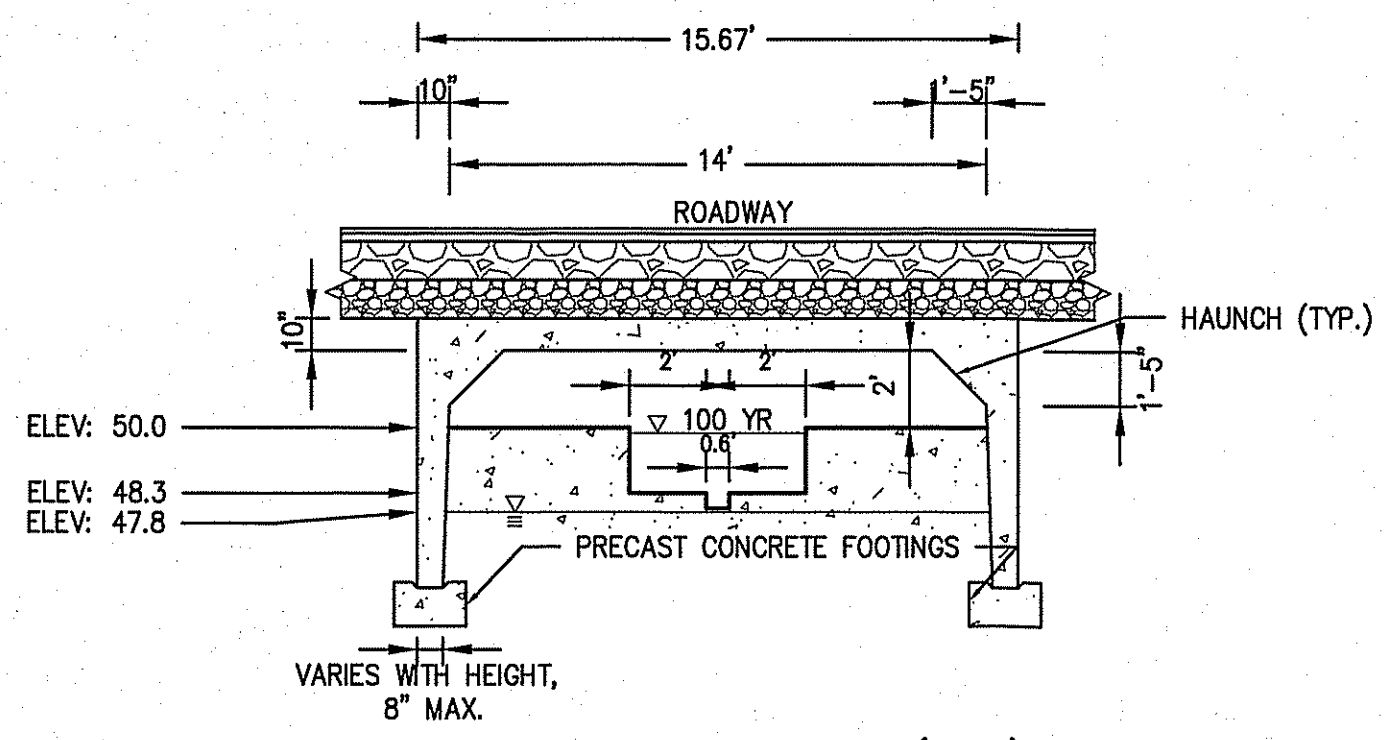

**CULVERT CROSS SECTION (B-B)**  
SCALE: 1"=2' (HORIZONTAL & VERTICAL)

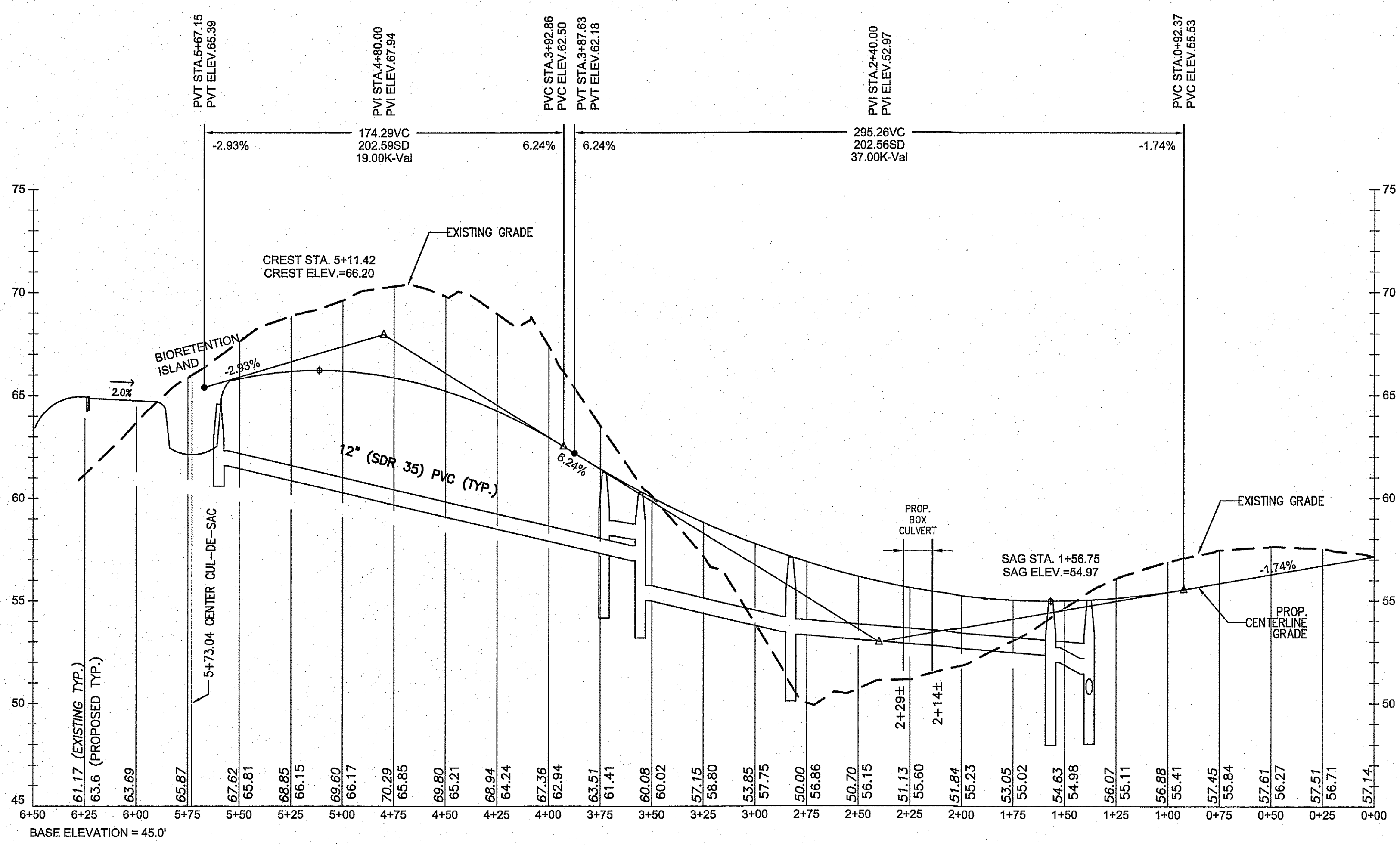

**PROPOSED ROAD PROFILE**  
SCALE: 1"=40' (HOR)  
1"=4' (VERT)

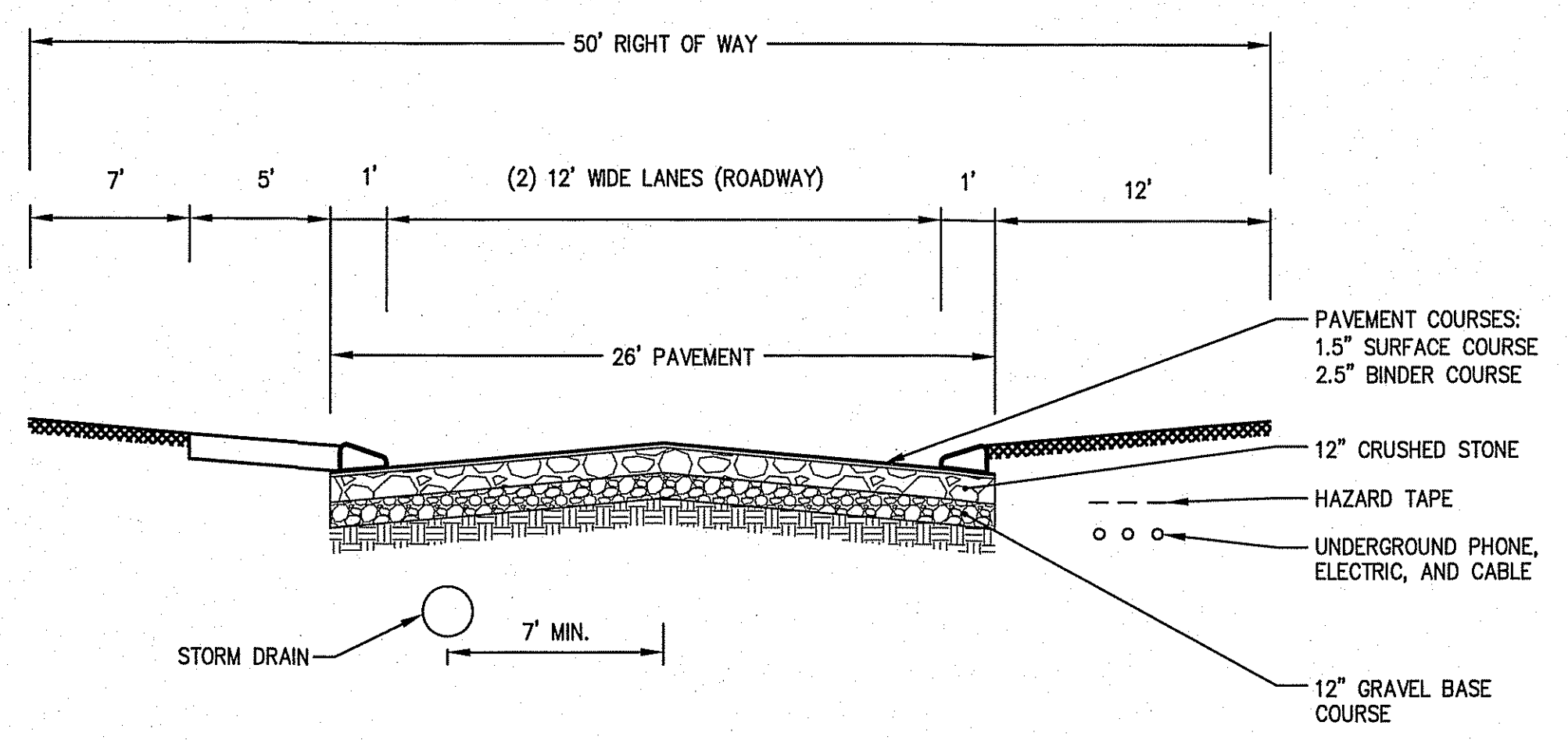

**TYPICAL ROAD CROSS SECTION**  
(NOT TO SCALE)

**The Morin-Cameron GROUP, INC.**  
CIVIL ENGINEERS | ENVIRONMENTAL CONSULTANTS  
LAND SURVEYORS | LAND USE PLANNERS  
447 BOSTON STREET - U.S. ROUTE 1, TOPSFIELD, MASSACHUSETTS 01868  
P: 978-87-2888, F: 978-87-2889, W: WWW.MORINCAMERON.COM

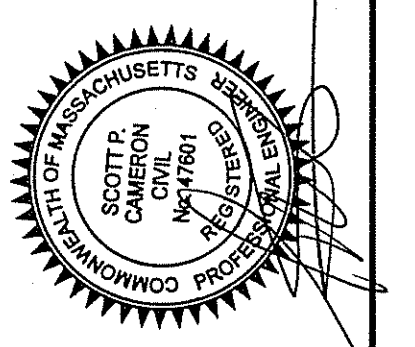

SURVEY BY: DY/RR  
DRAFTED BY: PY/SPC  
CHECKED BY: SPC  
APPROVED BY: SPC  
SCALE: 1"=40'  
DATE: MARCH 10, 2015

REVISIONS		DATE
NO.	DESCRIPTION	DATE
1	PLANNING BOARD COMMENTS	5/19/15

**PRELIMINARY SUBDIVISION PLAN OF LAND PROFILE**  
LOCATED AT  
**57 PERKINS ROW**  
(ASSESSOR'S MAP 99, LOT 25)  
TOPSFIELD, MASSACHUSETTS

**PLAN & PROFILE**  
DRAWING NO. **2 OF 4**